



## AVK SERVICE CONNECTION VALVE, DI, PN16

03/30-005

Tensile socket ends for PE pipes

AVK resilient seated service connection valves are designed with built-in safety in every detail. The wedge is vulcanized with AVK's own drinking water approved EPDM rubber compound. It features an outstanding durability due to the ability of the rubber to regain its original shape, the double bonding vulcanization process and the sturdy wedge design. The triple safety stem sealing system, the high strength stem and the thorough corrosion protection safeguard the unmatched reliability.

### Product description:

Service connection valve with push-in sockets. For drinking water and neutral liquids to max. 20° C. Note: The maximum working temperature is set according to the ISO9080 lifetime requirements for PE pipes, and is therefore not the max. temperature for the valve.

### Standards:

- Designed according to EN 1074 part 1 & 2, Designed according to EN 1171

### Test/Approvals:

- Hydraulic test according to EN 1074-1 and 2 / EN 12266
- Seat: 1.1 x PN (in bar), Body: 1.5 x PN (in bar). Operation torque test
- Approved according to ACS-France
- Belgaqua approved material
- Approved according to ÖVGW Certificate W 1.418
- Approved according to Swedish type approval 1350 certified by KIWA

### Features:

- Wedge of brass CW626N vulcanized with EPDM rubber – both brass and rubber certified for use in contact with drinking water– and shaped with guides and a special rubber profile ensuring low closing torques
- Stainless steel stem with rolled threads providing high strength
- Full circle thrust collar provides fixation of the stem and low free running torques
- Triple safety stem sealing with an NBR wiper ring, a polyamide bearing with four NBR O-rings and an EPDM rubber manchette
- EPDM bonnet gasket fixed in a recess
- Countersunk and sealed stainless steel bonnet bolts encircled by the bonnet gasket
- Full bore
- Low operating torque
- Sockets fitted with EPDM rubber seal rings and tension rings of POM
- Fusion bonded epoxy coating in compliance with DIN 3476 part 1 and EN 14901, GSK approved

### Accessories:

Handwheel, stem cap, extension spindle, street cover and tapping saddle.



Expect ... **AVR**



The designs, materials and specifications shown are subject to change without notice. To ensure correct installation and warranty coverage, please observe AVK's installation instructions.

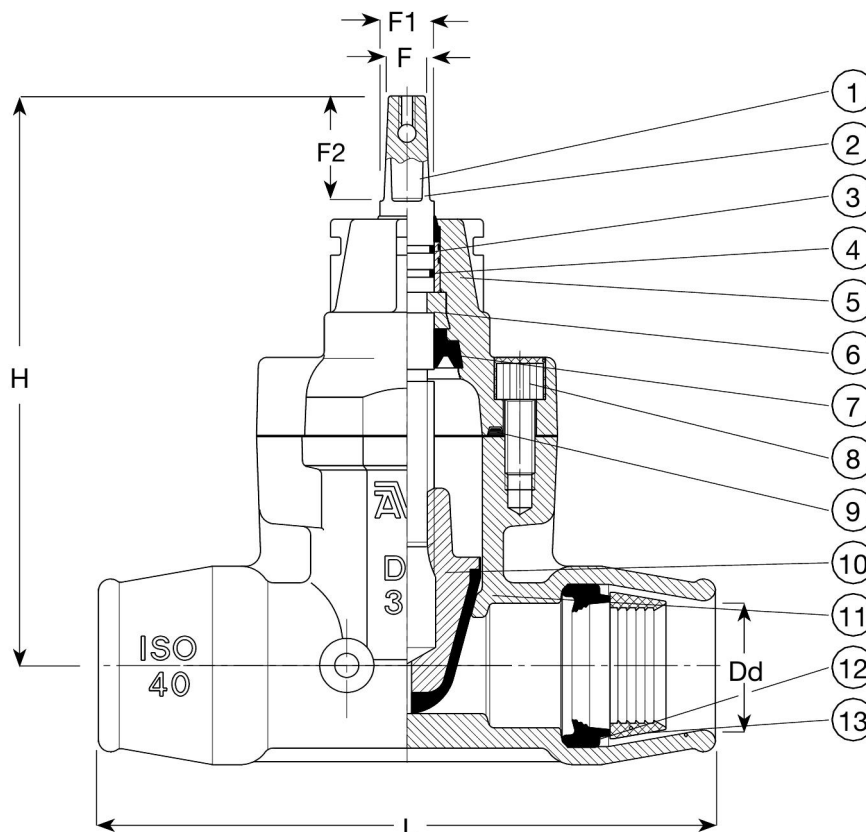

**Component list:**

1. Stem	Stainless steel 1.4104 (430F)	8. Bonnet bolt	Stainless steel A2, sealed with hot melt
2. Wiper ring	NBR rubber	9. Bonnet gasket	EPDM rubber
3. O-ring	NBR rubber	10. Wedge	Brass, DZR CW626N with EPDM
4. Bearing	Polyamide	11. Body	Ductile iron GJS-500-7 (GGG-50)
5. Bonnet	Ductile iron GJS-500-7 (GGG-50)	12. Seal ring	EPDM rubber
6. Thrust collar	Brass, DZR CW602N	13. Tension ring	POM
7. Manchette	EPDM rubber		

Components may be substituted with equivalent or higher class materials without prior notification.

**Reference nos. and dimensions:**

AVK ref. no.	DN mm	Dd mm	Product PN Class	L mm	H mm	F mm	F1 mm	F2 mm	Theoretical weight/kg
03-025-30-0046499	20	25	PN16	164	163	12	15	35	2.4
03-032-30-0046499	25	32	PN16	185	163	12	15	35	2.6
03-040-30-0046499	32	40	PN16	205	176	12	15	35	3.0
03-050-30-00	40	50	PN16	255	203	12	15	35	7.0
03-063-30-00	50	63	PN16	310	213	12	15	35	8.5