



AVK GATE VALVE, FLANGED, PN10/16 EN 558-2 S.14/DIN F4, DN40-600

06/30-0035

AVK gate valves are designed with built-in safety in every detail. The wedge is fully vulcanized with AVK's own drinking water approved EPDM rubber compound. It features an outstanding durability due to the ability of the rubber to regain its original shape, the double bonding vulcanization process and the sturdy wedge design. The triple safety stem sealing system, the high strength stem and the thorough corrosion protection safeguard the unmatched reliability.

Product description:

Flanged gate valve EN 558-2 S.14/DIN F4. For drinking water and neutral liquids to max. 70°C

Standards:

- Designed according to EN 1074 part 1 & 2, Designed according to EN 1171
- Face-to-face dimension according to EN 558 Table 2 Basic Series 14
- Standard flange drilling to EN1092-2 (ISO 7005-2), PN10/16

Test/Approvals:

- Hydraulic test according to EN 1074-1 and 2 / EN 12266
- Seat: 1.1 x PN (in bar), Body: 1.5 x PN (in bar). Operation torque test
- Approved according to ACS-France
- Approved according to DIN-DVGW Certificate NW-6203BN0117
- Approved according to KIWA Certificate K 6320
- Approved according to ÖVGW Certificate W 1.417
- Approved according to SVGW Certificate No. 0301-4606

Features:

- Fixed, integral wedge nut prevents vibration and ensures durability
- Wedge fully vulcanized with drinking water approved EPDM rubber and equipped with wedge shoes to provide smooth operation
- Large conical stem hole in the wedge prevents stagnant water
- Wedge and body guide rails ensure stable operation
- Stainless steel stem with wedge stop and rolled threads for high strength
- Full circle thrust collar provides fixation of the stem and low free running torques
- Triple safety stem sealing with an NBR wiper ring, a polyamide bearing with four NBR O-rings, and an EPDM rubber manchette
- Round EPDM bonnet gasket fixed in a recess
- Countersunk and sealed stainless steel bonnet bolts encircled by the bonnet gasket
- Full bore
- Low operating torque
- Fusion bonded epoxy coating in compliance with DIN 3476 part 1 and EN 14901, GSK approved
- DN 450-600 are fitted with stainless steel roller bearings providing low operating torques, ISO top flange, eye lifting bolts and optionally with DN 50 by-pass.

Accessories:

Stem cap, handwheel, extension spindle, street cover, flange adaptor and combi-flange



kiwa



Expect ... **AVR**

The designs, materials and specifications shown are subject to change without notice. This is due to the continuous development of our product programme.

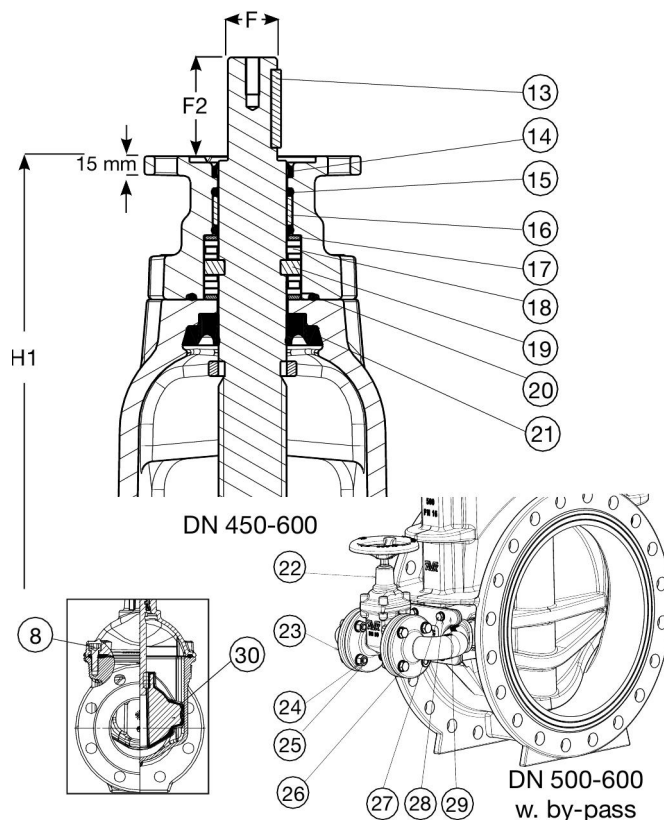
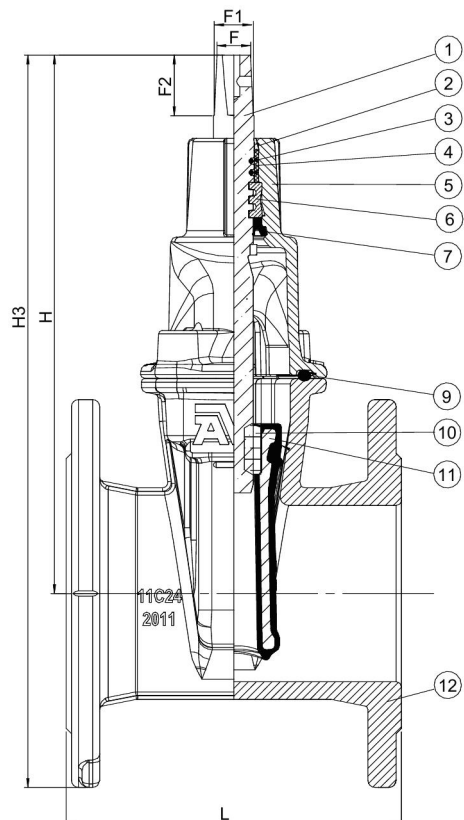

Component list:

1. Stem	Stainless steel 1.4104 (430F)	16. Bearing	Polyamide
2. Wiper ring	NBR rubber	17. Thrust washer	Stainless steel 1.4104 (430F)
3. O-ring	NBR rubber	18. Roller bearing	Stainless steel
4. Bearing	Polyamide	19. Thrust collar	Stainless steel 1.4104 (430F)
5. Bonnet	Ductile iron GJS-500-7 (GGG-50)	20. O-ring	NBR rubber
6. Thrust collar	Brass, DZR CW602N	21. Manchette	EPDM rubber
7. Manchette	EPDM rubber	22. By-pass valve	Ductile iron GJS-500-7 (GGG-50)
8. Bonnet bolt	Stainless steel A2, sealed with hot melt	23. By-pass bend	Ductile iron GJS-500-7 (GGG-50)
9. Bonnet gasket	EPDM rubber	24. Washer	Stainless steel A2
10. Wedge nut	Brass, DZR CW626N	25. Nut	Stainless steel A2
11. Wedge	Ductile iron, EPDM encapsulated	26. Bolt	Stainless steel A2
12. Body	Ductile iron GJS-500-7 (GGG-50)	27. Bolt	Stainless steel A2
13. Key	Stainless steel	28. Washer	Stainless steel A2
14. Wiper ring	NBR rubber	29. Plate for by-pass	Ductile iron GJS-500-7 (GGG-50)
15. O-ring	NBR rubber	30. Wedge shoe	Polyamide

Components may be substituted with equivalent or higher class materials without prior notification.

Reference nos. and dimensions:

AVK ref. no.	DN	Flange	L	H	H1	H3	F	F1	F2	Theoretical weight / kg
	mm	drilling	mm	mm	mm	mm	mm	mm	mm	
06-040-30-0146499 ⁽¹⁾	40	PN10/16	140	194	-	269	14	16	30	7.8
06-050-30-0146499 ⁽¹⁾	50	PN10/16	150	208	-	290	14	16	30	9.0
06-065-30-0146499 ⁽¹⁾	65	PN10/16	170	244	-	337	17	20	34	11
06-080-30-0146499 ⁽¹⁾	80	PN10/16	180	282	-	382	17	20	34	14
06-100-30-0146499 ⁽¹⁾	100	PN10/16	190	305	-	415	19	22	34	17
06-125-30-0146499 ⁽¹⁾	125	PN10/16	200	346	-	471	19	22	34	22
06-150-30-0146499 ⁽¹⁾	150	PN10/16	210	401	-	543	19	22	34	31
06-200-30-0046499 ⁽¹⁾	200	PN10	230	490	-	660	24	28	34	48

The designs, materials and specifications shown are subject to change without notice. This is due to the continuous development of our product programme.

Reference nos. and dimensions:

AVK ref. no.	DN	Flange	L	H	H1	H3	F	F1	F2	Theoretical weight / kg
	mm	drilling	mm	mm	mm	mm	mm	mm	mm	
06-200-30-0146499 ⁽¹⁾	200	PN16	230	490	-	660	24	28	34	48
06-250-30-004 ⁽²⁾	250	PN10	250	664	-	864	27	31	47	102
06-250-30-014 ⁽²⁾	250	PN16	250	664	-	864	27	31	47	102
06-300-30-004 ⁽²⁾	300	PN10	270	740	-	968	27	31	47	110
06-300-30-014 ⁽²⁾	300	PN16	270	740	-	968	27	31	47	110
06-350-30-006 ⁽³⁾	350	PN10	290	924	-	1184	32	37	55	220
06-350-30-016 ⁽³⁾	350	PN16	290	924	-	1184	32	37	55	220
06-400-30-006 ⁽³⁾	400	PN10	310	951	-	1241	32	37	55	240
06-400-30-016 ⁽³⁾	400	PN16	310	951	-	1241	32	37	55	240
06-450-30-006 ⁽⁴⁾	450	PN10	330	1167	1087	1487	Ø30	-	75	487
06-450-30-016 ⁽⁴⁾	450	PN16	330	1167	1087	1487	Ø30	-	75	487
06-500-30-006 ⁽⁴⁾	500	PN10	350	1142	1062	1500	Ø30	-	75	559
06-500-30-0060011 ⁽⁵⁾	500	PN10	350	1142	1062	1500	Ø30	-	75	559
06-500-30-016 ⁽⁴⁾	500	PN16	350	1142	1062	1500	Ø30	-	75	559
06-500-30-0160011 ⁽⁵⁾	500	PN16	350	1142	1062	1500	Ø30	-	75	559
06-600-30-006 ⁽⁴⁾	600	PN10	390	1285	1205	1705	Ø30	-	75	762
06-600-30-0060011 ⁽⁵⁾	600	PN10	390	1285	1205	1705	Ø30	-	75	762
06-600-30-016 ⁽⁴⁾	600	PN16	390	1285	1205	1705	Ø30	-	75	762
06-600-30-0160011 ⁽⁵⁾	600	PN16	390	1285	1205	1705	Ø30	-	75	762

(1) DVGW and KIWA approved
(2) KIWA, SVGW and ÖVGW approved
(3) SVGW approved
(4) With F14 top flange. Ø round stem w/keyway
(5) With F14 top flange and by-pass. Ø round stem w/keyway