

Data Sheet

Danfoss Icon™ Zigbee Module

Description



Danfoss Icon™ Zigbee Module is used to enable Zigbee integration on the Danfoss Icon™ 24V Master Controller.

The Zigbee Module is connected using a patch cable (2 m cable included in box).

Once connected to the Icon™ system can be accessed using a compatible Zigbee gateway.

Zigbee Module will enable:

- Remote access,
- Scheduling,
- Away, comfort and holiday mode,
- System alarms on your device e.g. low battery on thermostat.

Ordering

Product	Code number
Danfoss Icon™ Zigbee Module	088U1130

Technical data

Purpose of control	Zigbee communication device
Ambient temperature range, continuous use	0 °C to 40 °C
Frequency	2,4 GHz
Encapsulation (IP Class)	IP 20
Conformity declared acc. to following directives	RED, RoHS
Over voltage category	Class II
Supply voltage	5 V DC
Temperature for the ball pressure test	75 °C
Control pollution degree	Degree 2, normal household environment
Software class	Class A
Rated impulse voltage	4 kV
Operating time	Permanently connected
Temperature range, storage and transportation	-20 °C to +65 °C
Disposal instructions	The product must be disposed as electronic waste

Drawings

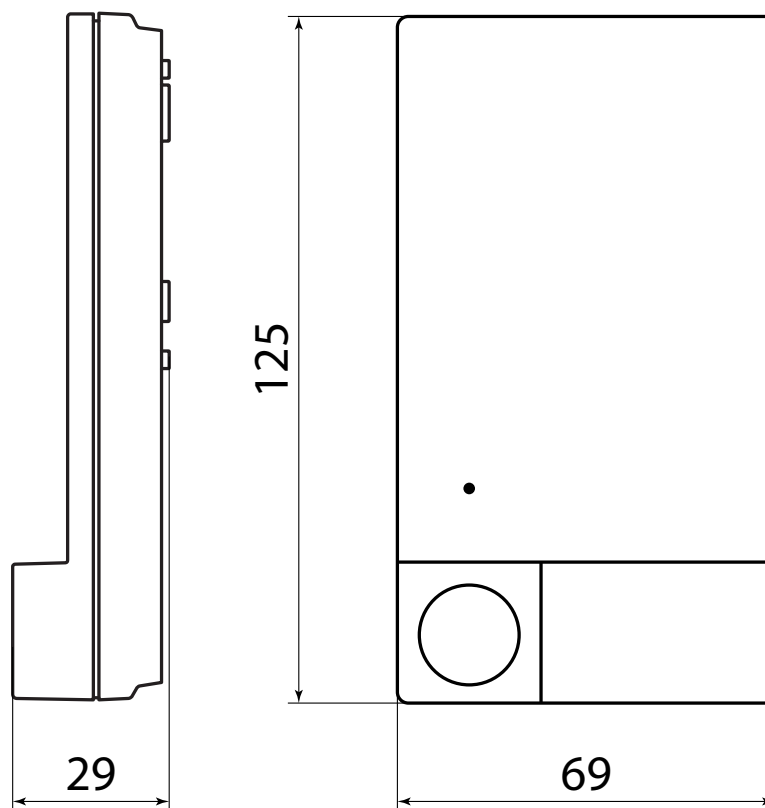

Danfoss A/S

Heating Segment • danfoss.com • +45 7488 2222 • E-Mail: heating@danfoss.com

Danfoss can accept no responsibility for possible errors in catalogues, brochures and other printed material. Danfoss reserves the right to alter its products without notice. This also applies to products already on order provided that such alterations can be made without subsequential changes being necessary in specifications already agreed. All trademarks in this material are property of the respective companies. Danfoss and all Danfoss logotypes are trademarks of Danfoss A/S. All rights reserved.