

Kogus | **Kirjeldus**

1

SBA 3-45 AW



Märkus! Reaalse toote väljanägemine võib erineda pildil kujutatust.

Toote kood:: Nõudmisel

Grundfos SBA 3-45 AW is an all-in-one submersible booster designed for pumping clean water for domestic use. The SBA is built on the proven SB platform and comes with an integrated control unit. This eliminates the need for an external pump controller in the house. It is silent when submerged and therefore a noiseless alternative to surface-mounted pumps. The pump is built from high quality composite and stainless steel materials that are resistant to corrosion.

The SBA 3-45 AW is equipped with a 15 m supply cable, and the maximum installation depth is 10 m below the water level, with a liquid temperature ranging from 0 °C to 40 °C.

The pump starts automatically when the pipe pressure falls below 2.2 bar.

The SBA 3-45 AW is ideal for operation in a well or ground tanks, as it easily prevents solid particles from entering the pump. The maximum particle size is 1 mm.

The pump features a float switch, which promises the user a convenient experience with automatic start/stop operation of the pump and provides dry running protection.

The pump is equipped with a side inlet/flexible hose with floating suction strainer.

The single-phase model is effectively protected against any accidental overload by built-in thermal protection.

The pump has built-in thermal protection, which immediately stops the pump if it overheats. Having cooled down, the pump automatically restarts when it reaches a normal temperature.

Vedelik:

Pumbatav vedelik: Vesi
Vedeliku temperatuurivahemik: 0 .. 40 °C
Valitud vedeliku temperatuur: 20 °C
Tihedus: 998.2 kg/m³

Tehnilised:

Nimijõudlus: 2.83 m³/h
Tõstekõrgus nom.: 30.1 m
Maks.tahkis: 1 mm
Karak. tolerantsid: ISO9906:2012 3B
Tagastusklapp: YES
Adjustable start pressure: N
Käivitusrõhk: 2.2 bar
Rated driver speed: 2800 p/min

Kogus	Kirjeldus
	Materjalid: Pumbapesa: Composite Tööratas: Composite
	Paigaldamine: Ümbritseva temperat. vahemik: -10 .. 50 °C Type of inlet connection: FLOATING STRAINER Pumba surveava: G 1" Maksimaalne paigaldussügavus: 10 m
	Elektriandmed: Sisendvõimsus P1: 1.05 kW Rated power - P2: 0.62 kW Vooluvõrgu sagedus: 50 Hz Nimipinge: 1 x 220-240 V Nimivool: 4.8 A Käivitusvool: 12 A Cos fii: 0.94 Kondensaator - töö: 13 µF/450 V Kaitseklass (IEC 34-5): IP68 Insulation class (IEC 85): F Built-in motor protection: YES Length of cable: 15 m Kaabli tüüp: H07RN-F 3G1 Kaablipistikü tüüp: SCHUKO
	Muu: Nettokaal: 9.83 kg Bruttokaal: 10.6 kg Tarnemaht: 0.031 m ³ Danish VVS No.: 391368045 Swedish RSK No.: 5850423 Finnish LVI No.: 4822548 Norwegian NRF no.: 9041858 Tunnustused: CE,VDE,WEEE Päritoluriik: IT Tollitariifi nr: 84137029

Nõudmised SBA 3-45 AW 50 Hz

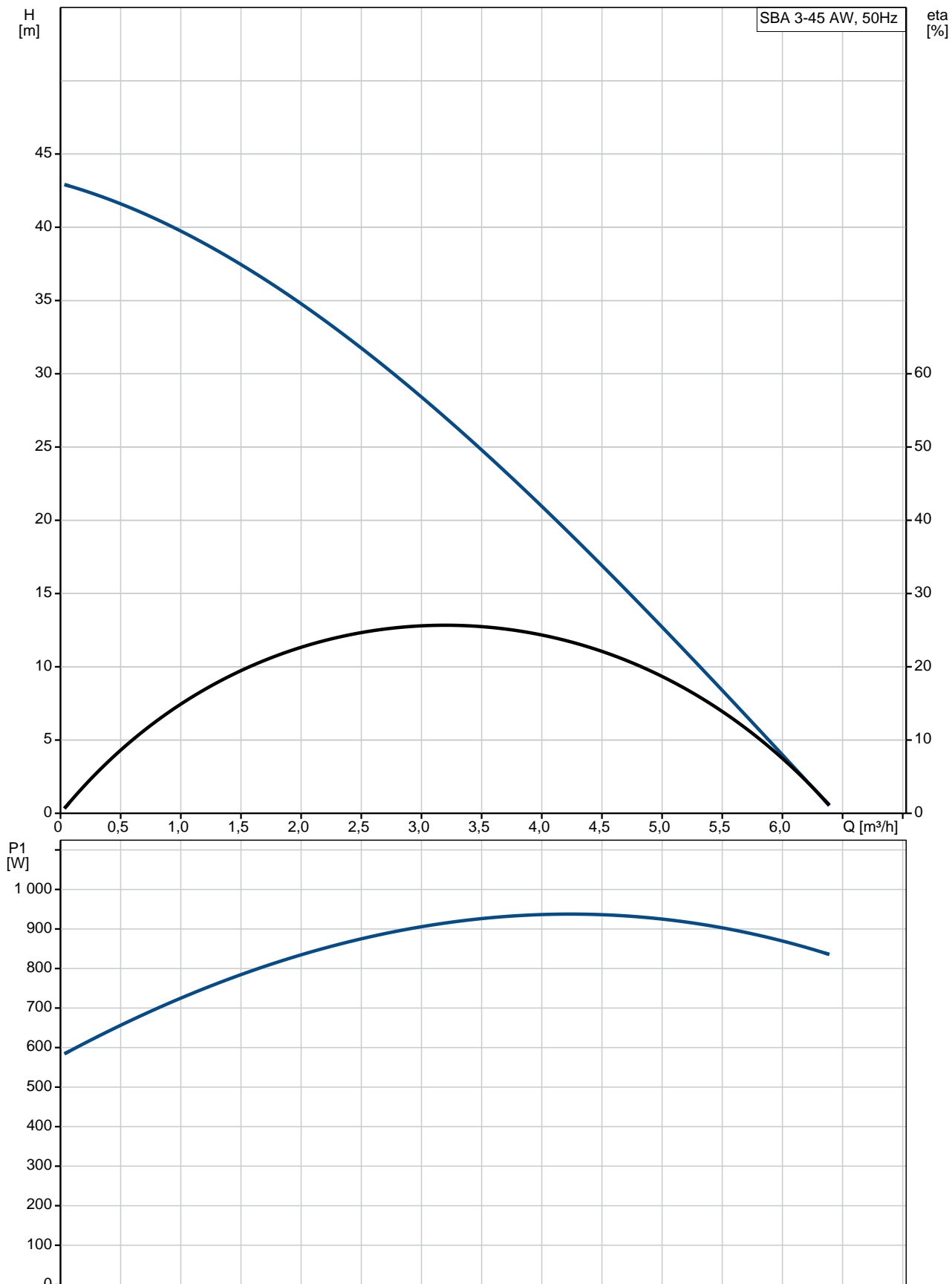

Nõudmisel SBA 3-45 AW 50 Hz

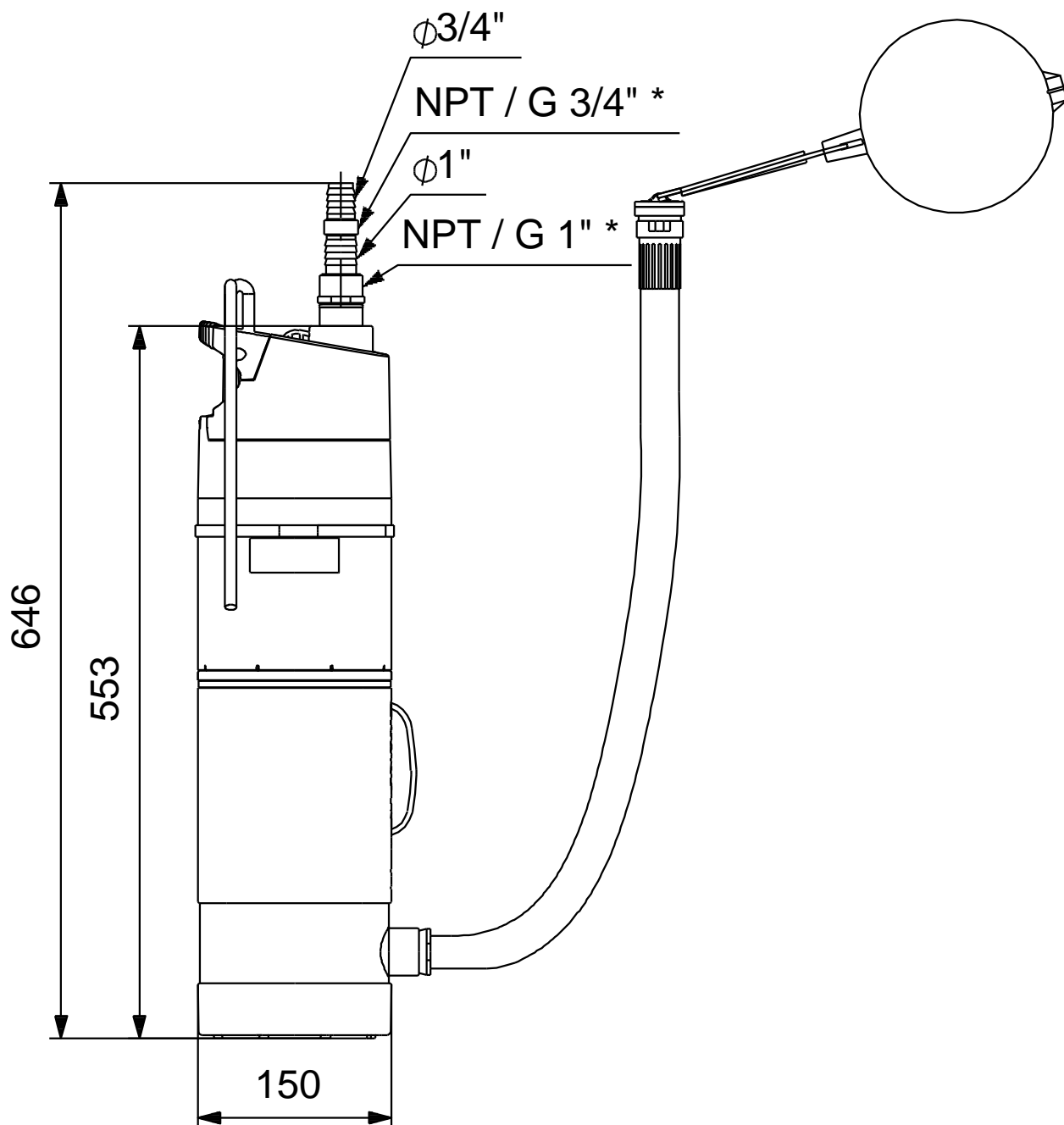

Märkus! Kõik mõõdud on [mm] kui pole teisiti tähistatud.
Lahtiütlus: see lihtsustatud mõõtjoonis ei näita kõiki detaile.