

**Kogus Kirjeldus**1 **SOLOLIFT2 C-3**

Märkus! Reaalse toote väljanägemine võib erineda pildil kujutatust.

Toote kood:: Nõudmisel

Sololift2 C-3 is a small, compact automatic lifting station suitable for pumping of greywater (w/o faeces) off places in private dwellings where wastewater cannot be led directly to the sewer by means of a natural downward slope.

Sololift2 C-3 is typically used for:

- cabinet showers, washbasins, bath tubs, washing machines (max. 90°C) and dishwashers in basements below sewer level or in connection with the renovation or modernisation of existing buildings, where the location may be remote from the main soil pipe so that a natural slope cannot be established.

Sololift2 C-3 is suitable for installation under a washbasin or particularly for confined space conditions in prewall constructions and built-in cabinets. Extremely low switching levels for lowest construction heights, advantageously in case of connection of a shower receptor.

The compact lifting station is equipped with

- Cable with or without plug (see technical data)
- Horizontal or vertical fastening possibility of discharge hose connector with several adaptors for pipes with Ø22-40mm
- Integrated non return valve
- Dry and high performance motor unit incl. thermal protection, level switch and controller
- Flexible connectors for inlet (adjustable in height) of pipes Ø36 or 40
- Manual anti clogging function and separate drain connection for service
- Venting valve with overflow protection
- Uplift fixation clips

Design according to EN12050-2 and production inspection by external institute with unique features focused on quick installation, long lasting operation and easy clean service.

Note: The discharge adaptor can be mounted vertical or horizontal. Vertical installation increase the flow (s. databooklet and curves)

Vedelik:

Pumbatav vedelik: Mistahes viskoosne vedelik

Maks. vedeliku temperatuur: 75(90) °C

Tihedus: 998.2 kg/m<sup>3</sup>

**Tehnilised:**

Tunnustused sildikul: CE,TR,VDEEMV,VDE,MORO

Karakt. tolerantsid: ISO9906:2012 3B

**Materjalid:**

Mahuti: Plastic

Kogus	Kirjeldus
	<b>Paigaldamine:</b>
	Pumba imiava: 32/36/40, 36/40/50
	Pumba surveava: 22/25/28/32/36/40
	Juhtmete arv: 3X0,75MM2
	<b>Elektriandmed:</b>
	Tarbitav võimsus - P1: 640 W
	Vooluvõrgu sagedus: 50 Hz
	Nimipinge: 1 x 220-240 V
	Nimivool: 3.1 A
	Cos fii - võimsustegur: 0.9
	Nimikiirus: 2800 p/min
	Kaitseklass (IEC 34-5): IP44
	Isolatsiooniklass (IEC 85): F
	Kaabli pikkus: 1.2 m
	Kaabli tüüp: H05VV-F-3G
	Kaablipistikü tüüp: SCHUKO
	<b>Muu:</b>
	Nettokaal: 7.75 kg
	Bruttokaal: 9.3 kg
	Danish VVS No.: 614365632
	Swedish RSK No.: 5886547
	Finnish LVI No.: 4965315
	Norwegian NRF no.: 9045711
	Päritoluriik: RS
	Tollitariifi nr: 84137021

## Nõudmisel SOLOLIFT2 C-3 50 Hz

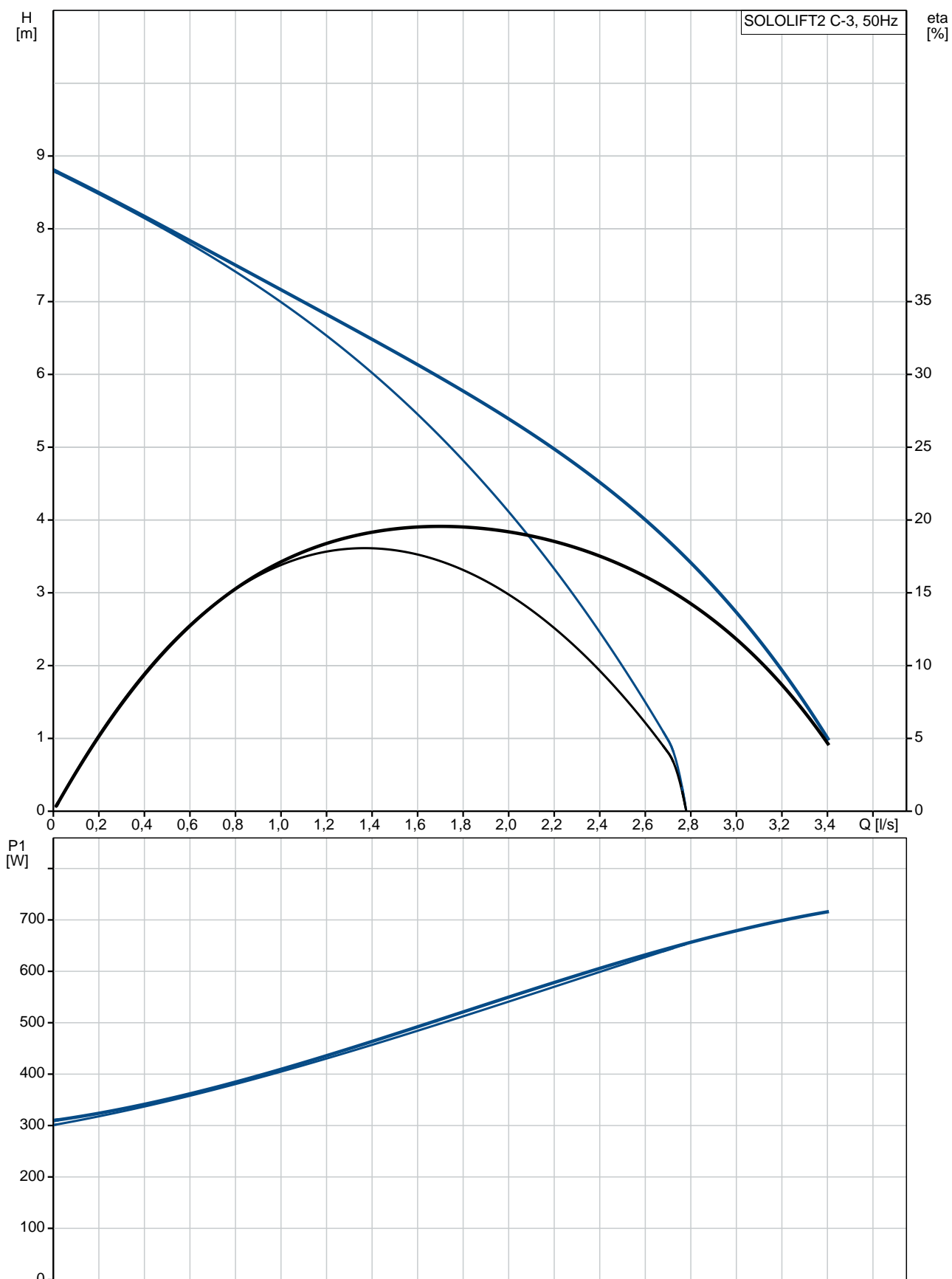

## Nõudmised SOLOLIFT2 C-3 50 Hz

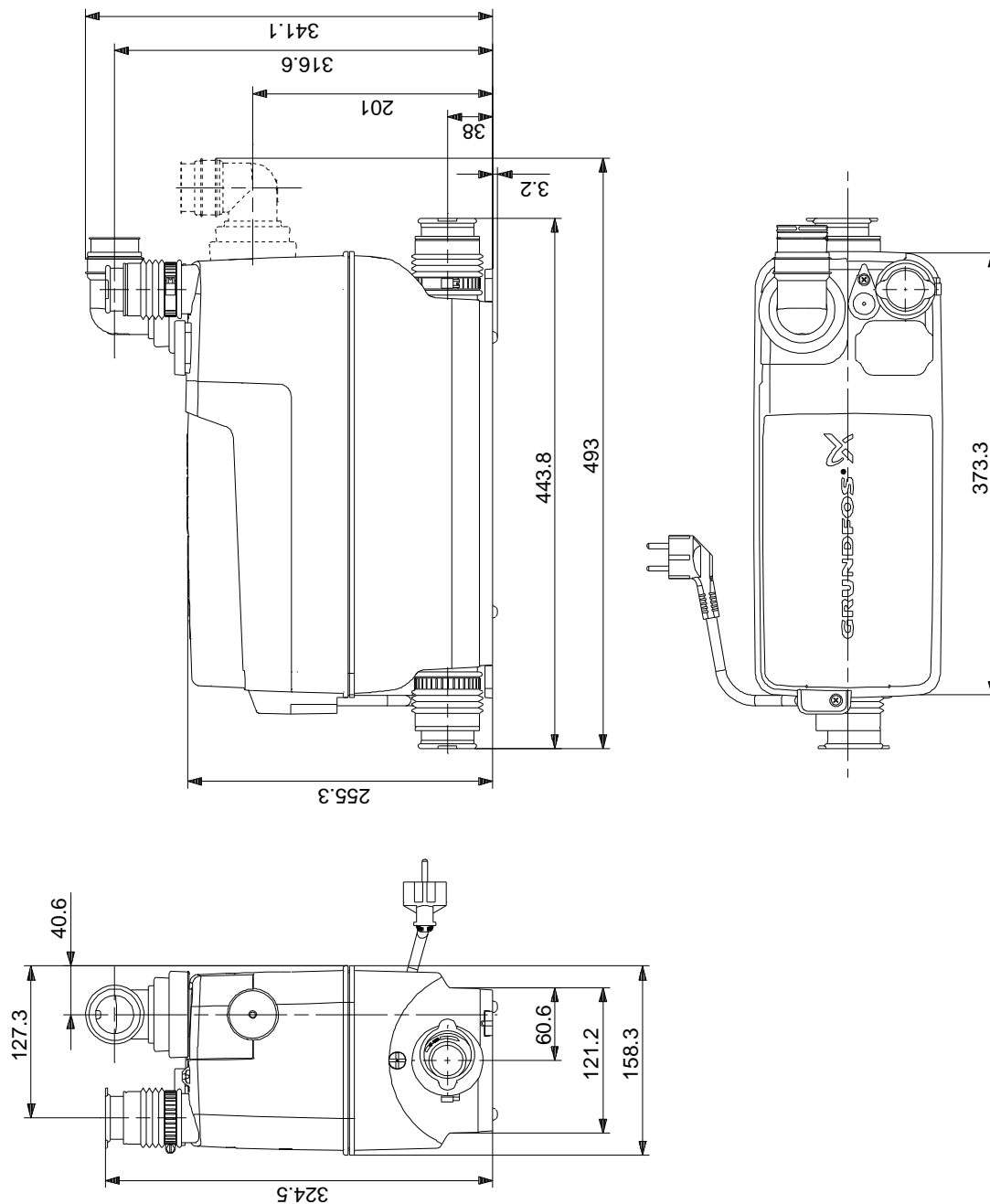

Märkus! Kõik mõõdud on [mm] kui pole teisiti tähistatud.  
Lahtiütlus: see lihtsustatud mõõtjoonis ei näita kõiki detaile.