

Kogus Kirjeldus

1

SOLOLIFT2 WC-1

Märkus! Reaalse toote väljanägemine võib erineda pildil kujutatust.

Toote kood:: Nõudmisel

Sololift2 WC-1 is a small, compact automatic lifting station suitable for pumping of wastewater off places in private dwellings where wastewater cannot be led directly to the sewer by means of a natural downward slope.

Sololift2 WC-1 is suitable for pumping wastewater from a toilet containing toilet paper and faeces with an additional connection on the lid for e.g. a washbasin.

The pumping of liquids containing other material may cause faults and limit the scope of our guarantee.

Sololift2 WC-1 is typically used to dewater:

- toilet and washbasin in basements below sewer level, in connection with the renovation or modernisation of existing buildings, where the location may be remote from the main soil pipe so that a natural slope cannot be established.

The compact lifting station is equipped with

- Cable with or without plug (see technical data)
- Horizontal or vertical fastening possibility of discharge hose connector with several adaptors for pipes with Ø22-40mm
- integrated non return valve
 - Dry and high performance motor unit incl. thermal protection, pressure switch and controller
 - DN100 toilet connection hose
 - Flexible connectors for inlet (adjustable in height) of pipes Ø36 or 40
 - Slot for an alarm board with buzzer (accessory)
 - Manual anti clogging function and separate drain connection for service
 - Venting valve with overflow protection
 - Uplift fixation clips

Design according to EN12050-3 and production inspection by external institute with unique features focused on quick installation, long lasting operation and easy clean service.

Note: The discharge adaptor can be mounted vertical or horizontal. Vertical installation increase the flow (s. databooklet and curves)

Vedelik:

Pumbatav vedelik: Mistahes viskoosne vedelik

Maks. vedeliku temperatuur: 50 °C

Tihedus: 998.2 kg/m³

Tehnilised:

Tunnustused sildikul: CE,TR,VDEEMV,VDE,MORO

Karakt. tolerantsid: ISO9906:2012 3B

Materjalid:

Mahuti: Plastic

Kogus	Kirjeldus
	Paigaldamine:
	Pumba imiava: 32/36/40, DN 100
	Pumba surveava: 22/25/28/32/36/40
	Juhtmete arv: 3X0,75MM2
	Elektriandmed:
	Tarbitav võimsus - P1: 620 W
	Vooluvõrgu sagedus: 50 Hz
	Nimipinge: 1 x 220-240 V
	Nimivool: 3 A
	Cos fii - võimsustegur: 0.92
	Nimikiirus: 2800 p/min
	Kaitseklass (IEC 34-5): IP44
	Isolatsiooniklass (IEC 85): F
	Kaabli pikkus: 1.2 m
	Kaabli tüüp: H05VV-F-3G
	Kaablipistikü tüüp: SCHUKO
	Muu:
	Nettokaal: 7.95 kg
	Bruttokaal: 9.55 kg
	Danish VVS No.: 614363432
	Swedish RSK No.: 5886545
	Finnish LVI No.: 4965312
	Norwegian NRF no.: 9045714
	Päritoluriik: RS
	Tollitariifi nr: 84137021

Nõudmisel SOLOLIFT2 WC-1 50 Hz

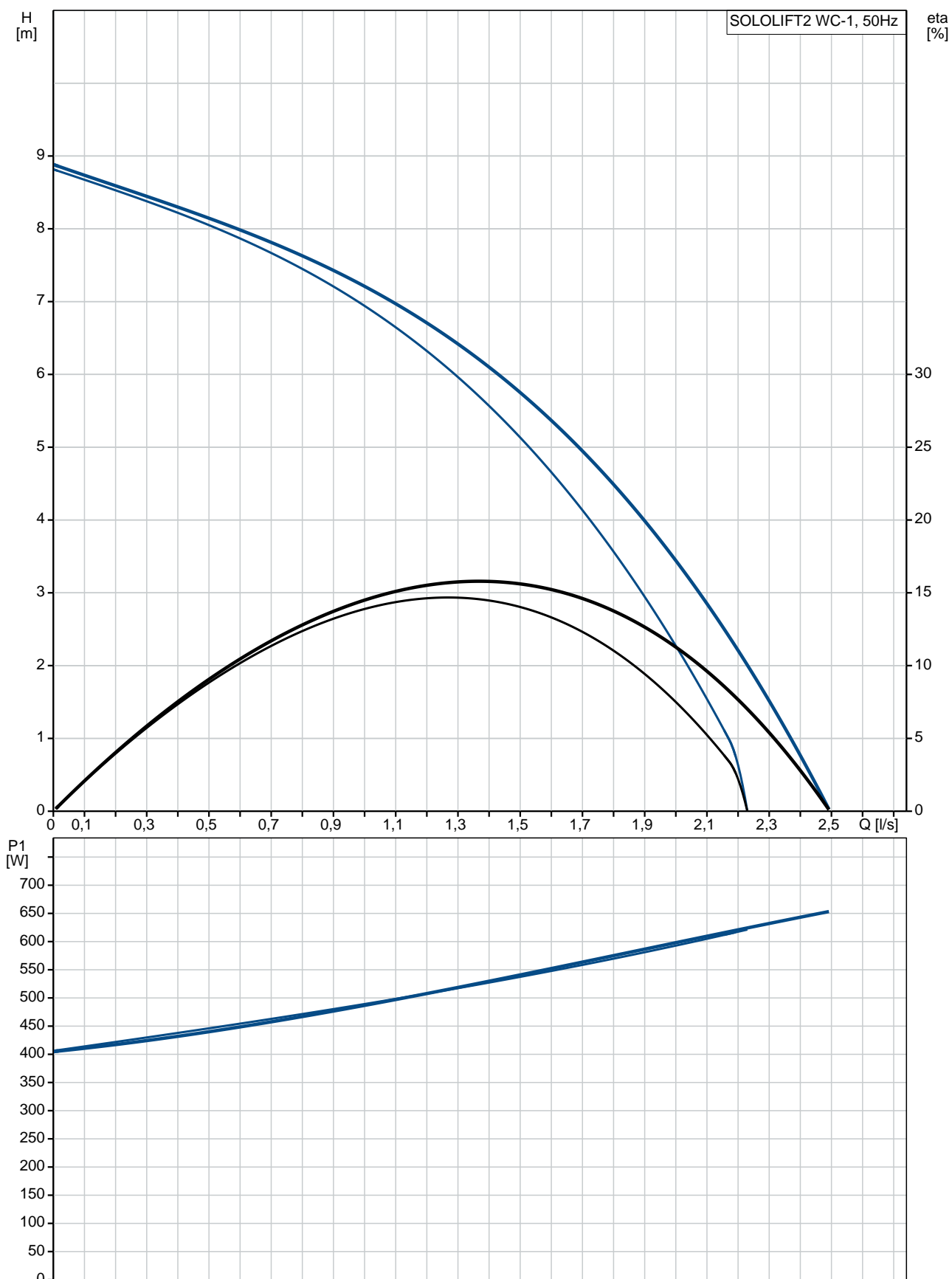

Nõudmisel SOLOLIFT2 WC-1 50 Hz

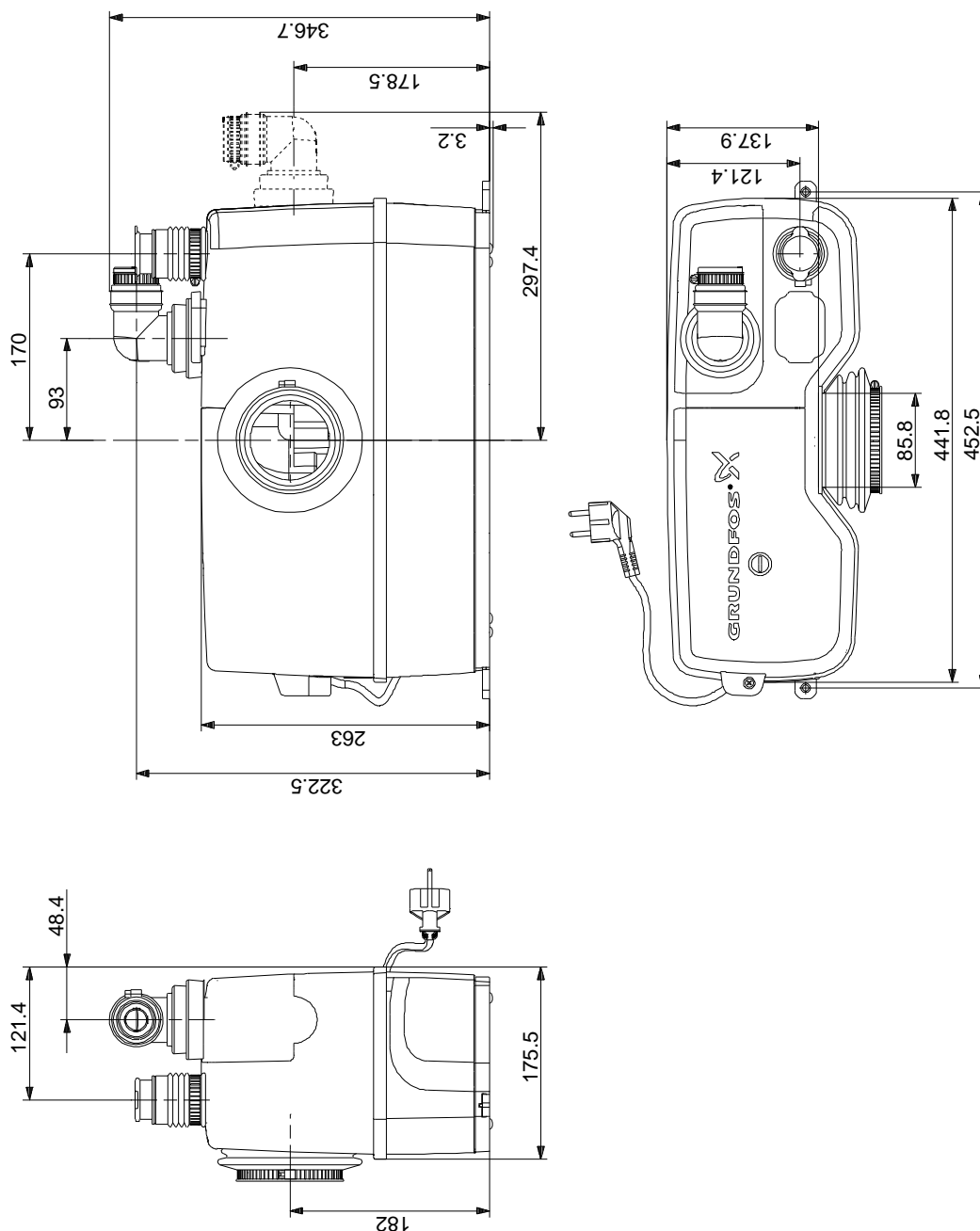

Märkus! Kõik mõõdud on [mm] kui pole teisiti tähistatud.
Lahtiütlus: see lihtsustatud mõõtjoonis ei näita kõiki detaile.