

SUNSYSTEM®

WATER HEATERS FOR HEAT PUMP SYSTEMS

serie **SWP**

150, 200, 300, 400, 500 L

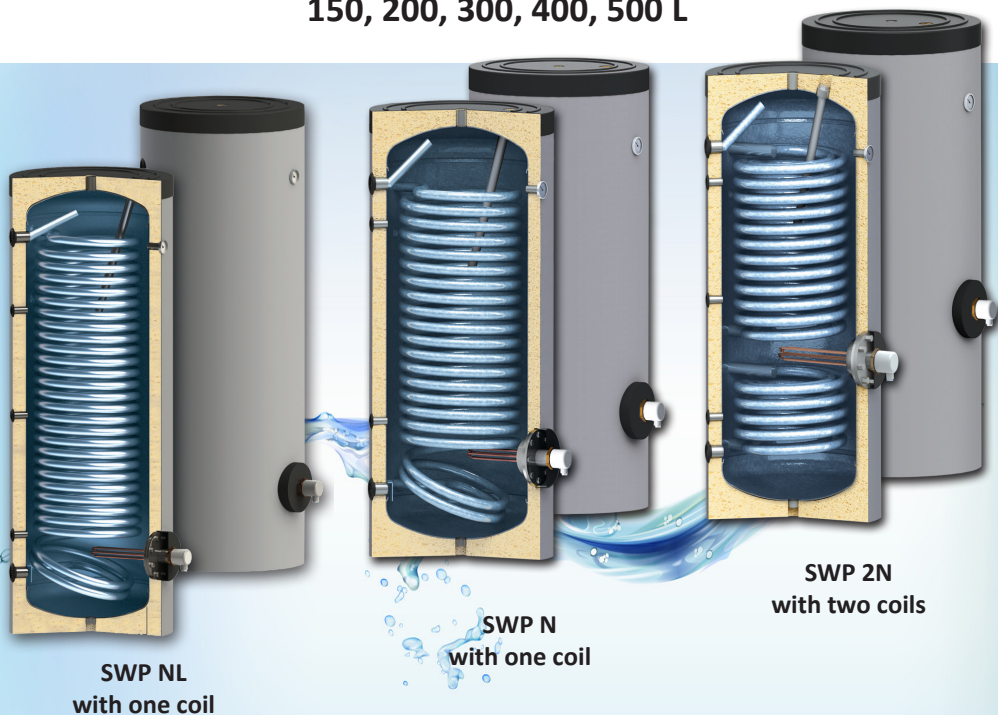

INSTALLATION and OPERATION MANUAL

Version 0.3.3



TABLE OF CONTENTS

1.	INSTRUCTIONS TO INSTALLER	4
1.1.	Requirements to water tank installation room	4
1.2.	Requirements for installation.	4
2.	DESCRIPTION ON SWP	5
3.	CONNECTING OF RELIEF VALVE TO WATER TANK.....	12
4.	TECHNICAL PARAMETERS.....	14
4.1.	SWP NL - with one coil.....	14
4.2.	SWP N - with one coil.....	16
4.3.	SWP 2N - with two coils.....	18
5.	TRANSPORT AND PACKAGING.....	20
6.	WARRANTY	20
7.	RECYCLING	23

Dear Customers,

We strongly hope that the appliance you have bought from us will contribute to creating comfort at you homes and decreasing the energy expenditure.

This manual contains important information for the safe and correct installation, start-up and trouble-free operation and maintenance of the water heater.

The water heater can be used for producing of domestic hot water (DHW) only in the manner described in this manual.

The application and any other was the area of operation is not recommended by the manufacturer and is not responsible for the occurrence of defects or failures.

1. INSTRUCTIONS TO INSTALLER

	<p>The preparation, installation and commissioning must be performed by an authorized installer / service.</p>
---	---

During installation and operation, the country specific requirements and regulations must be observed:

- local construction regulations on installation of water tank; weight of the boiler to comply with the stability of the floor of the room where it will be installed.
- regulations and norms concerning the fitting of the installation with safety devices.
- safety during installation - personal

protective equipment

	<p>Use only original SUNSYSTEM parts.</p>
---	--

1.1. Requirements to SWP installation room

When choosing a room for tank installation observe the following requirements:

- to have a drainage channel. Some maintenance procedures require draining of all water from the tank.
- Thermal insulation of the room. This provides efficiency of the appliance and prevents the water from freezing.

1.2. Requirements for installation.

- The length of connecting pipes between the water tank and consumer must be as short as possible.
- Before connecting the water tank to the installation, check all screw connections (plug and etc.). In very rare cases - during transportation, loading and unloading operations - the screw connections may be loosen.
- Before commissioning, check the installation for leaks
- Do not exceed the working pressure of 3 bar for buffer tank and 6 bar for hygienic stainless steel coil.
- If there is a risk of freezing of water in the tank - drain the tank completely or let the water tank works continuously.

2. DESCRIPTON

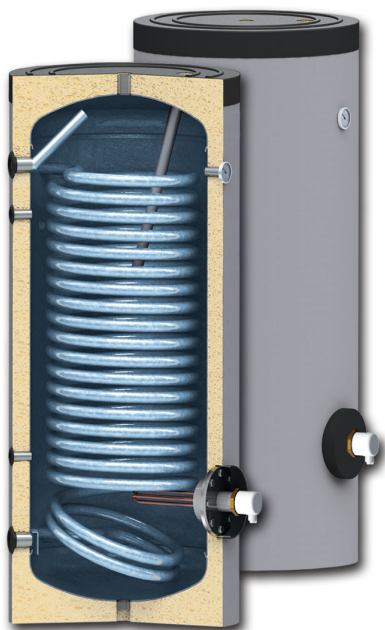

by means of titanium enamel and anode protection.

- All threads are internal.
- Convenient inspection opening.
- High efficiency heat exchanger coil/coils (SWP N/SWP 2N).

The height of SWP NL model is compensated by its smaller diameter; heat exchanger coil with increased surface.

- Easy installation.
- Suitable for solar water heating, space-heating, and heat pump systems with large number of consumers

2.1. High efficiency insulation and outer casing

The quality of the insulation of a water heater is a key factor for its heat conservation capability and energy efficiency.

All water heaters SWP series have a high efficiency insulation (DIN 4753, part 8) and outer casing of PVC with RAL 9006.

2.2. Water tank

Water tank is made of low-carbon steel S235JR, tightly covered with titanium enamel on the inside. It is then baked to produce a smooth and uniform deposition - free glazing. Thus the domestic hot water remains clean, and the water tank is protected against corrosion.

All threads are internal (see technical parameters).

2.3. Electric heating element (option).

Outlet connection of electric heating element 1 ½" :

- 3000W/230V; 4500W/230V;
- 6000W/230V; 7500W/400V.

Water heaters for heat pump systems

SWP series includes:

SWP NL one coil water heater

SWP N one coil water heater

SWP 2N double coil water heater

With extra-sized heat exchanger surface; suitable for solar water heating, space-heating, and heat pump systems with large number of consumers

Product features:

- Floor standing
- Vertical modifications
- High efficiency insulation and outer casing of PVC
- Complex corrosion protection realized



The connection of the electric heating element to the electric power supply must be done by a qualified electricians.
When connect the heating element to the electric network, make sure that it is properly grounded.



Water tank, L	Connection	Length L, mm	Current, W	Voltage, V
150	1 1/2"	210	3000	230/400
200	1 1/2"	210	3000	230/400
300	1 1/2"	320	4500	230/400
400	1 1/2"	410	6000	230/400
500	1 1/2"	590	7500	230/400

In the table of technical parameters is specified location for installation of electric heating element.

Wiring diagrams

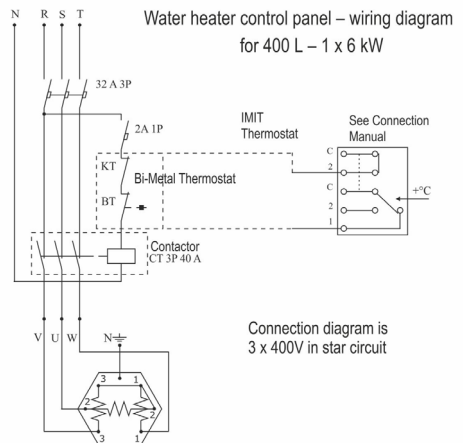
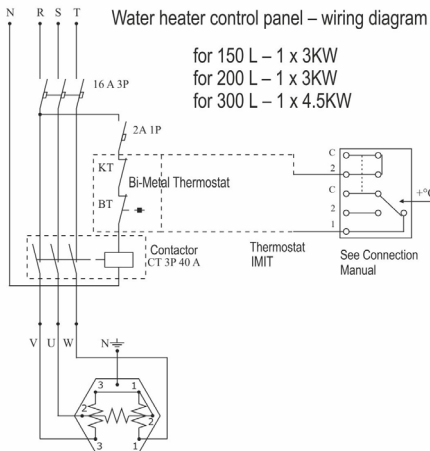

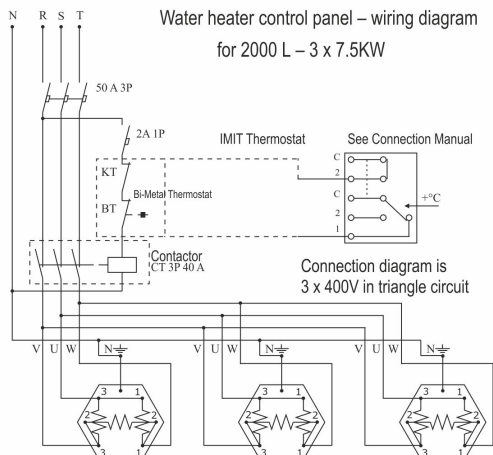
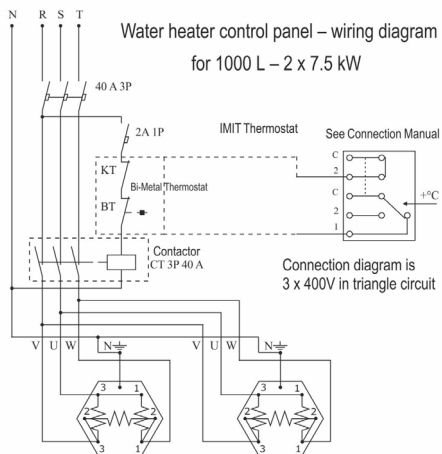
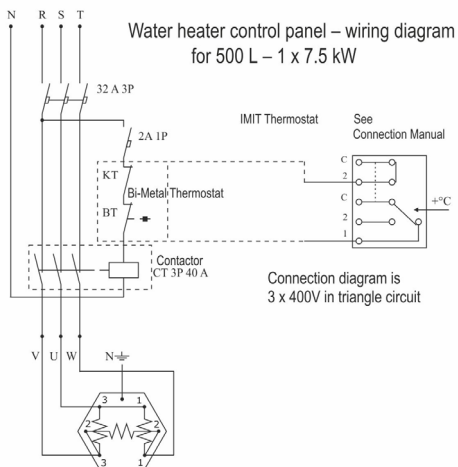

2.4. Thermometer



2.5. Cathodic Corrosion Protection of Enamelled Steel tanks for domestic hot water (DIN 4753, part 6)

 **Anode must be checked every two years. Replace the anode when needed.**

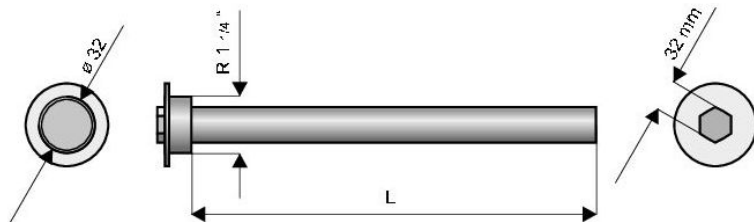

Magnesium anode - connection Size and Length:

Water tank Capacity, L	Anode connection size, mm	Anode length, mm	Anode Pcs.
150	1 1/4"	230	1
200	1 1/4"	300	1
300	1 1/4"	400	1
400, 500	1 1/4"	600	1

2.6. Inspection opening

Large and convenient inspection opening located in the lower part of the tank gives access for maintenance and cleaning. The opening is closed by an enameled flange cover which may have a sleeve for fitting electric heater if necessary.

 **Do not reuse the gasket of flange. Replace the gasket at each inspection (opening).**

Water tank Capacity, L	Flange diameter, mm	Opening diameter, mm
150÷500	180	110

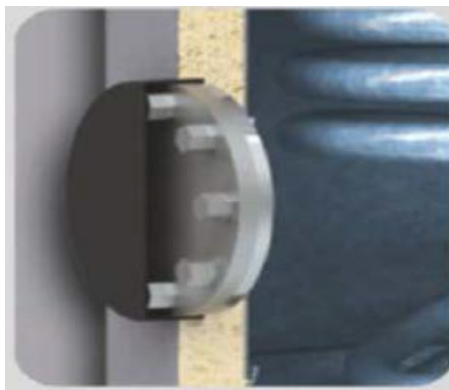

2.7.Thermostat (option).

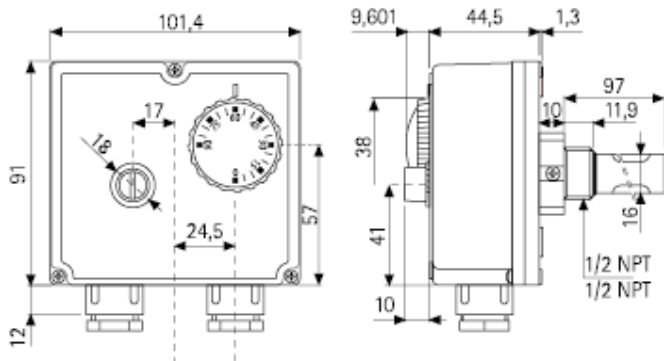

sheme 1

The thermostat may be adjusted by the user within the range $30^{\circ}\text{C} \div 80^{\circ}\text{C}$, and the thermal protection would go off in case the water reaches 95°C .

This is an adjustable double THERMOSTAT which is designed to regulate the water temperature and ensures safety tolerance; it can be manually adjusted (TLSC model) or automatically adjusted (TLSC/A model).



CONFORMITY TO STANDARDS

This product is in conformity with:

- EN 60730-1 and subsequent editions;
- EN 60730-2-9

CONFORMITY TO REGULATIONS

This product complies with:

- Low Voltage Directive 73/23 EEC
- Electromagnetic Compatibility Directive 89/336/EC

TECHNICAL CHARACTERISTICS

Temperature range – regulation- $0^{\circ}\text{C} \div 90^{\circ}\text{C}$;

limit - $90^{\circ}\text{C} \div 110^{\circ}\text{C}$;

Tolerance

Regulation $\pm 5\text{k}$,

limit – $15\text{ k}; -6\text{ k}$ (depends on the type)

Temperature differential

Regulation $6 \pm 2\text{ k}; 4 \pm 1\text{ k}$ (depends on the type)

Limit $25 \pm 8\text{ k}; 15 \pm 8\text{ k}$ (depends on the type)

Automatic adjustment (TLSC/A) and manual adjustment (TLSC).

Degree of protection = IP 40

Insulation class = I.

Temperature change rate = $< 1\text{K}/\text{min}$.

Maximal temperature point: 80°C

Maximal temperature for electric lamp: 125°C

Accumulation temperature: $15^{\circ}\text{C} \div 55^{\circ}\text{C}$

Maximum pressure of the cartridge: 10 bar

Constant time: $< 1''$

Electric connection:

C-1 ADJ.: $10(2,5)\text{A}/250\text{V}^{\circ}$;

C-2 ADJ.: $6(2,5)\text{A}/250\text{V}^{\sim}$;

C-1LIM.:0,5A/250V~;
 C2LIM.:10(2,5)A/250V~;
 Terminal – circuit breaker or
 switch-on contacts.
 Switch-on action – 2B.
 Place of installation – normal.
 Type of wire – M20 x 1.5.



WARNING !
 All installation operations,
 including manual adjustments,
 must be fulfilled by a qualified
 specialist following all safety
 conditions.

INSTALLATION AND CONNECTION .

Safety instructions:

Before connecting the thermostat, make sure that THE UNIT TO BE THERMALLY CONTROLLED (water heater, pump, etc.) IS NOT CONNECTED to the power supply network, and is in compliance with the instructions in Figure

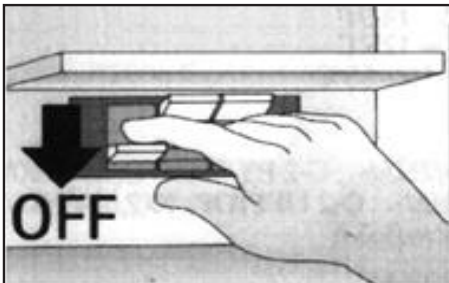

scheme 2

a) See scheme 3 and scheme 4.

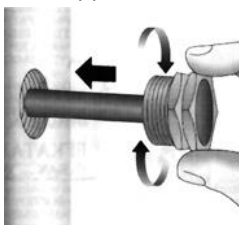

scheme 3

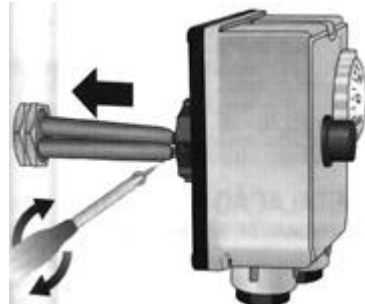

scheme 4

b) Unscrew the three bolts and remove the front part of the thermostat. Unravel the power supply wires and connect them to the terminals of the thermostat (Figure 5) following the instructions.

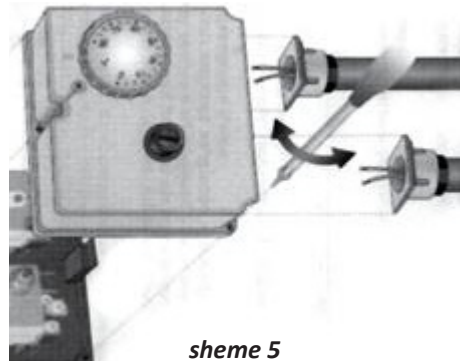

scheme 5

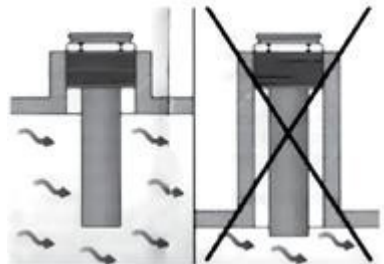

scheme 6

NOTE: See Scheme 6.

To close the front part, the cartridge opening must align with the coupling of the adjustment knob.

**CONNECTION
(Scheme 7)**

LIMITATION

TERMINAL 2 – opens the circuit when the temperature rises.

TERMINAL C – common contact.

THERMOSTAT

TERMINAL 1 – opens the circuit when the temperature rises.

TERMINAL 2 – closes the circuit when the temperature rises

TERMINAL C – common contact

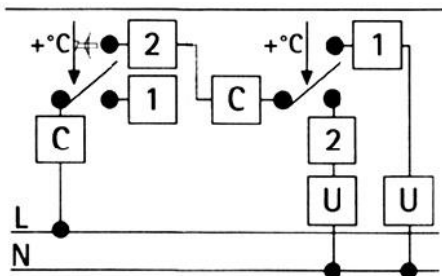

scheme 7

**TEMPERATURE ADJUSTMENT
(see Scheme 8)**

A – Reset button (only for TLSC)

B – Knob for temperature adjustment

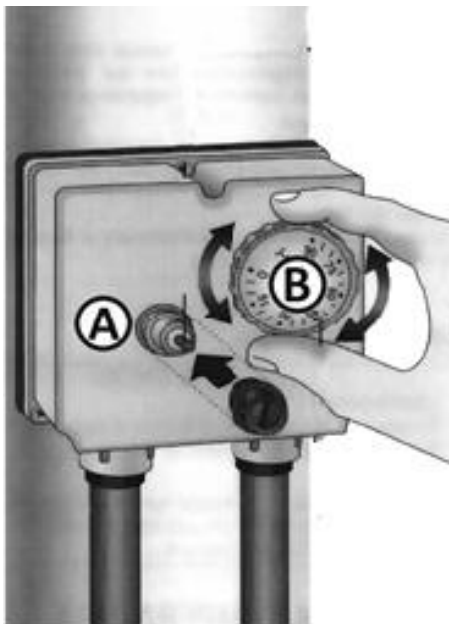

scheme 8

2.8. Screws with rubber head

Included at standard water tank package. Screws with rubber heads are mounted at the bottom of the vertical water tank / 150 to 500 l / - use to level the tank.

3. CONNECTING OF SAFETY RELIEF VALVE TO WATER TANK

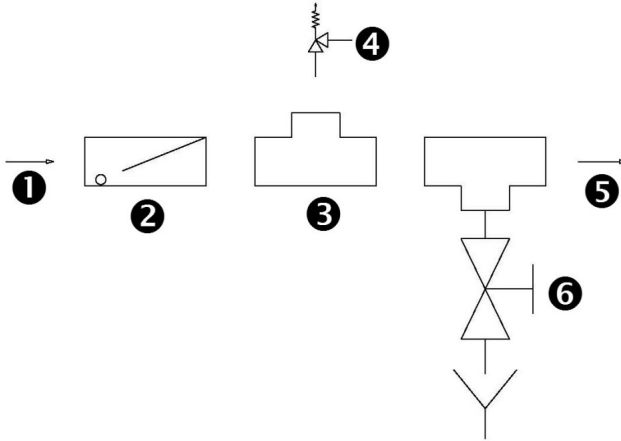

1	Cold water inlet - water supply
2	Check (return) valve
3	Tee
4	Safety (relief) pressure valve
5	Cold water inlet - water tank
6	Stopcock (drainage)

	<p>Stop (Shut-off) valves should never be installed between a safety (relief) valve and the tank. It is recommended once a year to check the operation of the safety valve.</p>
---	--



4. TECHNICAL PARAMETERS to serie SWP

4.1. SWP NL - with one coil

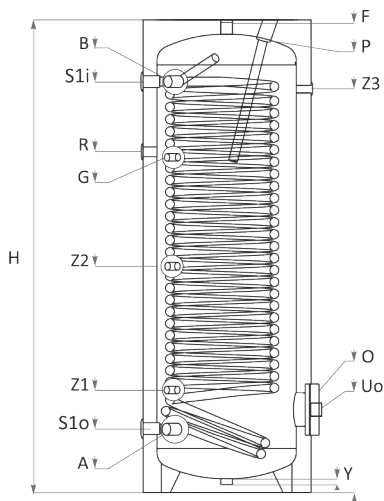
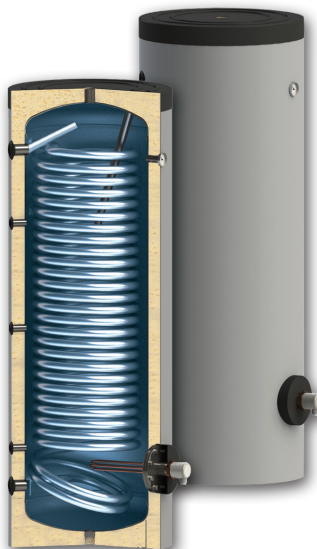

SWP NL 300-500

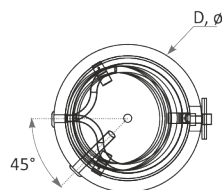



		SWP NL 300	SWP NL 400	SWP NL 500
Capacity	L	300	400	500
Height	mm	1695	1669	1895
Diameter	D, mm	Ø 610	Ø 710	Ø 710
Insulation		50 mm rigid PU		
Operating pressure/Maximum temperature	bar/°C	10/95	10/95	10/95
Test pressure	bar	15	15	15
Electric heating (optional)	κW	1 x (4.5)	1 x (6)	1 x (7.5)
Weight	kg	131	175	196
Cold water inlet	A, mm	Rp1"/228	Rp1 ^{1/4} "/260	Rp1 ^{1/2} "/250
Hot water outlet	B, mm	Rp1"/1476	Rp1 ^{1/4} "/1420	Rp1 ^{1/2} "/1643
Recirculation	R, mm, Rp ^{3/4} "	Rp ^{3/4} "/1224	Rp1"/1180	Rp1"/1392
Operating pressure/Maximum temperature coils S1	bar/°C	16/110	16/110	16/110
Test pressure coils S1	bar	25	25	25
Coils capacity S1	L	20.4	23.6	28.3
Coils Heat exchange surface S1	m ²	3.3	3.9	4.6
Inlet/Outlet Lower coi S1	S1i/ S1o, mm, Rp1"	1476/228	1390/260	1626/250
Prolonged power acc. to DIN 4708; 10°C/80°C/45°C, S1	kW (m3/h)	90(2.21)	115(2.70)	130(3.19)
NL- power coefficient at 60°C, S1	NL 60°C	11	14	18
Pressure drop Δp, S1	Δp, mbar	230	379	569
Inspection opening / flange	O, Ø, mm	Ø110x180/ 298	Ø110x180/ 345	Ø110x180/ 345
Sleeve for Electric element on inspection opening flange	Uo, mm, Rp1 ^{1/2} "	298	345	345
Drain sleeve	Y, mm, Rp1"	30	30	30
Anode	P, mm, Rp1 ^{1/4} "	1695	1524	1750
Additional sensor sleeve	Z1/Z2/Z3, mm, Rp ^{1/2} "	368/812/1204	420/695/1100	433/966/1372
Air vent sleeve	F, mm, Rp1"	1695	1669	1895
Sensor sleeve for thermostat	G, mm, Rp1/2"	1220	1176	1298

4.2. SWP N - with one coil

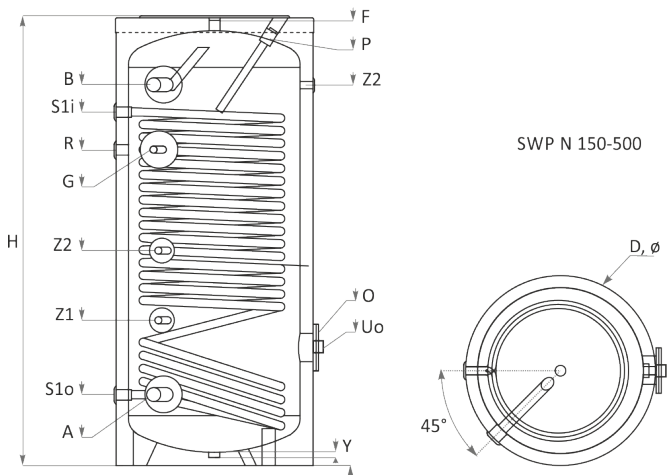
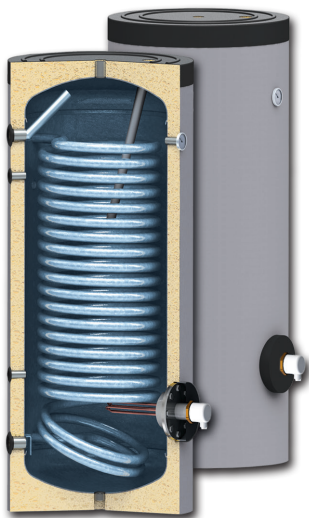



		SWP N 150	SWP N 200	SWP N 300	SWP N 400	SWP N 500
Capacity	L	150	200	300	400	500
Height	mm	1070	1340	1420	1470	1720
Diameter	D, mm	∅ 560	∅ 560	∅ 650	∅ 750	∅ 750
Insulation		50 mm rigid PU				
Operating pressure/Maximum temperature	bar/°C	10/95	10/95	10/95	10/95	10/95
Test pressure	bar	15	15	15	15	15
Electric heating (optional)	κW	1 x (3)	1 x (3)	1 x (4.5)	1 x (6)	1 x (7.5)
Weight	kg	70	90	121	165	190
Cold water inlet	A, mm	Rp1"/182	Rp1"/182	Rp1"/215	Rp1 ^{1/4} "/270	Rp1 ^{1/2} "/270
Hot water outlet	B, mm	Rp1"/895	Rp1"/1160	Rp1"/1182	Rp1 ^{1/4} "/1240	Rp1 ^{1/2} "/1453
Recirculation	R, mm, Rp ^{3/4} "	Rp ^{3/4} "/652	Rp ^{3/4} "/922	Rp ^{3/4} "/1007	Rp1"/1105	Rp1"/1206
Operating pressure/ Maximum temperature coils S1	bar/°C	16/110	16/110	16/110	16/110	16/110
Test pressure coils S1	bar	25	25	25	25	25
Coils capacity S1	L	8.6	11.7	14.8	17.2	20
Coils Heat exchange surface S1	m ²	1.4	1.9	2.3	2.8	3.3
Inlet/Outlet Lower coi S1	S1i/ S1o, mm, Rp1"	872/182	1122/182	1155/215	1210/270	1350/270
Prolonged power acc. to DIN 4708; 10°C/80°C/45°C, S1	κW (m3/h)	40.4(0.99)	51(1.25)	62(1.52)	75(1.84)	84(2.06)
NL- power coefficient at 60°C, S1	NL 60°C	6	8	20	27	34
Pressure drop Δp, S1	Δp, mbar	120	150	400	600	710
Inspection opening / flange	∅,∅, mm	∅110x180/ 309	∅110x180/ 309	∅110x180/ 320	∅110x180/ 450	∅110x180/ 450
Sleeve for Electric element on inspection opening flange	Uo,mm, Rp1 ^{1/2} "	309	309	320	450	450
Drain sleeve	Y, mm, Rp1"	30	30	30	30	30
Anode	P, mm, Rp1 ^{1/4} "	1070	1340	1410	1318	1568
Additional sensor sleeve	Z1/Z2/Z3, mm, Rp1 ^{1/2} "	410/-/ 868	410/650/ 1138	430/700/ 1170	565/720/ 1204	560/800/ 1453
Air vent sleeve	F, mm, Rp1"	1070	1340	1410	1460	1710
Sensor sleeve for thermostat	G, mm, Rp1/2"	697	967	1054	1054	1206

4.3. SWP 2N - with two coils

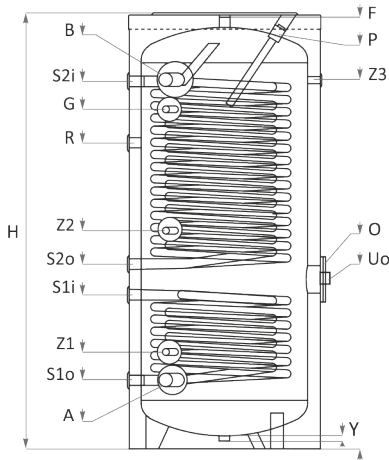
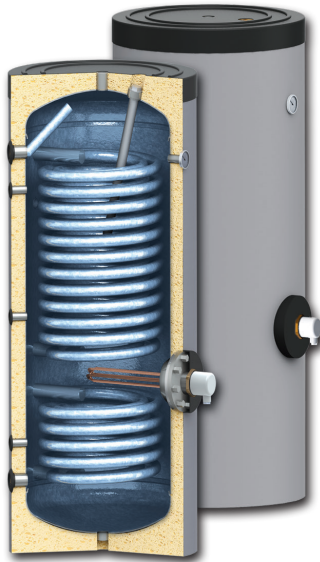

SWP 2N 300 - 500

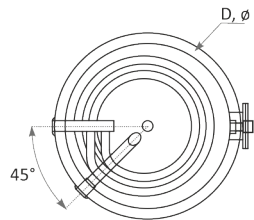



		SWP 2N 300	SWP 2N 400	SWP 2N 500
Capacity	L	300	400	500
Height	mm	1420	1490	1720
Diameter	D, mm	Ø 660	Ø 750	Ø 750
Insulation		50 mm rigid PU		
Operating pressure/Maximum temperature	bar/°C	10/95	10/95	10/95
Test pressure	bar	15	15	15
Electric heating (optional)	κW	1 x (4.5)	1 x (6)	1 x (7.5)
Weight	kg	145	198	236
Cold water inlet	A, mm	Rp1"/215	Rp ^{1/4} "/240	Rp ^{1/2} "/240
Hot water outlet	B, mm	Rp1"/1185	Rp ^{1/4} "/1240	Rp ^{1/2} "/1475
Recirculation	R, mm, Rp ^{3/4} "	Rp ^{3/4} "/1007	Rp1"/1105	Rp1"/1206
Operating pressure/Maximum temperature coils S1/S2	bar/°C	16/110	16/110	16/110
Test pressure coils S1/S2	bar	25	25	25
Coils capacity S1/S2	L	6.5/16.1	10/18.9	11.8/26
Coils Heat exchange surface S1/S2	m ²	1.2/2.7	1.5/3.2	1.8/4.36
Inlet/Outlet Lower coi S1	S1/ S1o, mm,Rp ^{3/4} "	435/215	562/240	606/240
Inlet/Outlet Upper coi S2	S2/ S2o, mm,Rp ^{3/4} "	1105/587	1195/665	1446/726
Prolonged power acc. to DIN 4708; 10°C/80°C/45°C, S1/S2	κW (m3/h)	53(1.30)/ 75(1.84)	62(1.52)/ 82(2.01)	72(1.77)/ 94(2.31)
NL- power coefficient at 60°C, S1/S2	NL 60°C	11/17	14/22	18/29
Pressure drop Δp, S1/S2	Δp, mbar	55/70	70/85	90/120
Inspection opening / flange	O,Ø, mm	Ø110x180/ 545	Ø110x180/ 620	Ø110x180/ 666
Sleeve for Electric element on inspection opening flange	Uo,mm, Rp1 ^{1/2} "	545	620	666
Drain sleeve	Y, mm, Rp1"	30	30	30
Anode	P,mm,Rp1 ^{1/4} "	1410	1318	1575
Additional sensor sleeve	Z1/Z2/Z3, mm, Rp1 ^{1/2} "	325/697/1170	380/755/1155	380/858/1455
Air vent sleeve	F, mm, Rp1"	1410	1480	1710
Sensor sleeve for thermostat	G, mm, Rp1/2"	1095	1145	1453

5. TRANSPORT AND PACKAGING

We recommend to transport the water tank to the installation site in its packaging placed on the pallet, and stretch foil. During transport and installation, depending on the weight, appropriate

safety equipment must be used in accordance with Directive 2006/42/EC. When transporting items weighing more than 30 kg, the use of pallet jack, fork truck or other hoisting devices is a must.

Capacity of Water tank, L					
	150	200	300	400	500
Pallet Dimensions	600 x 600	600 x 600	700 x 700	800 x 800	800 x 800

6. WARRANTY

6.1. Manufacturing defects and materials guarantee

NES Ltd. expressly guarantees that the products it manufactures shall be free from defects in materials and workmanship which can prevent from normal operation under proper and normal use, installation and maintenance for the intended functions of the products, for a period set out in the warranty certificate of the respective water heater model you have bought. The warranty period begins from the date indicated in the purchase invoice. If a product or any component there of is determined to be defective in manufacture or materials, NES Ltd. will repair or replace the defective component or product

which case the customer must make the claim at the shop immediately after noticing the defect as it is provided for in the general conditions of sale.

6.2. Exclusions and Limitations of Warranty Coverage

a) The customer can claim warranty during warranty period of respective product immediately after any defects have been determined, except for in case of noticeable defects at the moment of purchase, in

- 1) Accidents, installation on movable structures, negligence, improper care or nonconformity.
- 2) Failure to observe the installation, use and maintenance instructions set forth in the installation manual of respective product.
- 3) Improper installation and use as well as changes, especially if they are not made by authorized after-sale service personnel of NES Ltd.
- 4) Testing and operation pressures greater than values established by NES Ltd. and set forth in product manuals, or use of water with characteristic values exceeding:
 - Dissolvable salts – 500 mg/l;
 - Calcium carbonate – 200 mg/l;
 - Free carbon dioxide – 50 mg/l;
 - ph content – minimum 5 and maximum 12.

5) Freeze, flood, natural disasters or third party actions as well as any interventions into normal functioning conditions of water heaters and the control of NES Ltd.

The customer as well should monitor the anticorrosion system (magnesium anode). He should periodically check the magnesium anode and replace it depending on the geographic location at intervals depending on the type of water (soft or hard) of the region where the water heater is being used.

b) The warranty certificate is considered void for water heaters whose serial identification number has been modified, removed or blurred, or cannot be expressly attested.

c) Damages in the appearance of products shall not be considered as defects except for those ones which cause losses during operation or change technical characteristics of water heaters set forth in brochures.

d) NES Ltd. preserves the right, in case of replacement, to deliver another model of water heater in order to fulfill approved warranty claims when the original model is not being manufactured.

6.3. Claiming warranty

Every customer who has purchased a water heater from NES Ltd., and who has good reasons to lay a warranty claim, shall proceed as follows:

a) Immediately notify in writing:

- 1) The installer, or the company that has sold the water heater to him, or
- 2) The distributor firm, or
- 3) The commercial representative of NES Ltd. in the region.

For this purpose the claimant shall fill out a claim form; the latter shall be accompanied by the document proving the purchase of the water heater (invoice) with the date of purchase in it.

b) After receiving the claim form, NES Ltd. considers it and makes decision whether the claim has grounds, and whether the defect is within the scope of the warranty set forth in this certificate for limited warranty; after which informs the customer as to its decision and the steps he shall do.

c) The return of a product cannot be done without written authorization issued by the Quality Department. The return procedure shall be according to RMA (Return Material Authorization).

d) If on customer's request, and when there is reason for urgency, the customer demands immediate replacement of the product he has claimed warranty for, before making the decision as to the claim, said request shall be accompanied by a Purchase requisition from the Commercial Department. After decision for satisfaction of the claim has been made, the Purchase requisition mentioned above will be annulled by issuing a receipt for returned goods; with this receipt the customer can purchase another product with the same price in case the claim has proved grounded.

e) NES Ltd. reserves the right to make in situ reports from the claims they have received for the purpose of checking every aspect that might be useful for better consideration of warranty claims; for this reason the customer shall not make any

changes in installation conditions which are reasons for the claim without prior written consent of the Technical Department.

6.4. Limitation of liability

a) NES Ltd. is not liable before the customer, neither directly nor indirectly, for any non-fulfillment or delay at applying the warranty obligations which might originate from external pressure of other circumstances outside NES Ltd

b) The liability of NES Ltd. under this Warranty Certificate is limited to the abovementioned obligations and up to the sum in accordance with the purchase receipt of the product to be claimed; excluded is any liability for indirect damages such as loss of data at information applications, loss of production, thermal variations at the service, etc. which do not violate the applicable regulations of any country concerning product liability.

c) Abovementioned warranty limitations will be applied in any cases, and when they do not violate the regulations in any country concerning product liability. If this circumstance annuls some of preceding clauses, annulment will refer only to this clause, while the others will remain valid. In conclusion, excluded is application of any Regulation pointed out in this Warranty which violates the Law 23/July 10, 2003 and Directive 1999/44/EU concerning water heaters and their use on the territory of the EU.

d) Any other warranty right that is not mentioned in this Warranty Certifi-

cate is excluded.

7. RECYCLING AND WASTE DISPOSAL

Submit all packaging material for recycling according to the local regulations and requirements.

At the end of life cycle of each product its components are due to be disposed of in conformity with regulatory prescriptions. According to Directive 2002/96/EC regarding electrical and electronic equipment waste, disposal thereof is required separately from the normal flow of solid household waste. Obsolete equipment shall be collected separately from other recyclable waste containing materials with adverse effect on health and environment.

Expired appliances must be collected separately from other recyclable waste containing substances hazardous to health and environment.

Both metal and non-metal parts are sold out to licensed organizations for recyclable metal or non-metal waste collection. In any case they should not be treated as household waste.





NES
new energy systems

tel.: +359 700 17 343

www.burnit.bg